

**ZRT**

# ZRT-250

## RIGHT HAND MOTOR MOUNTING

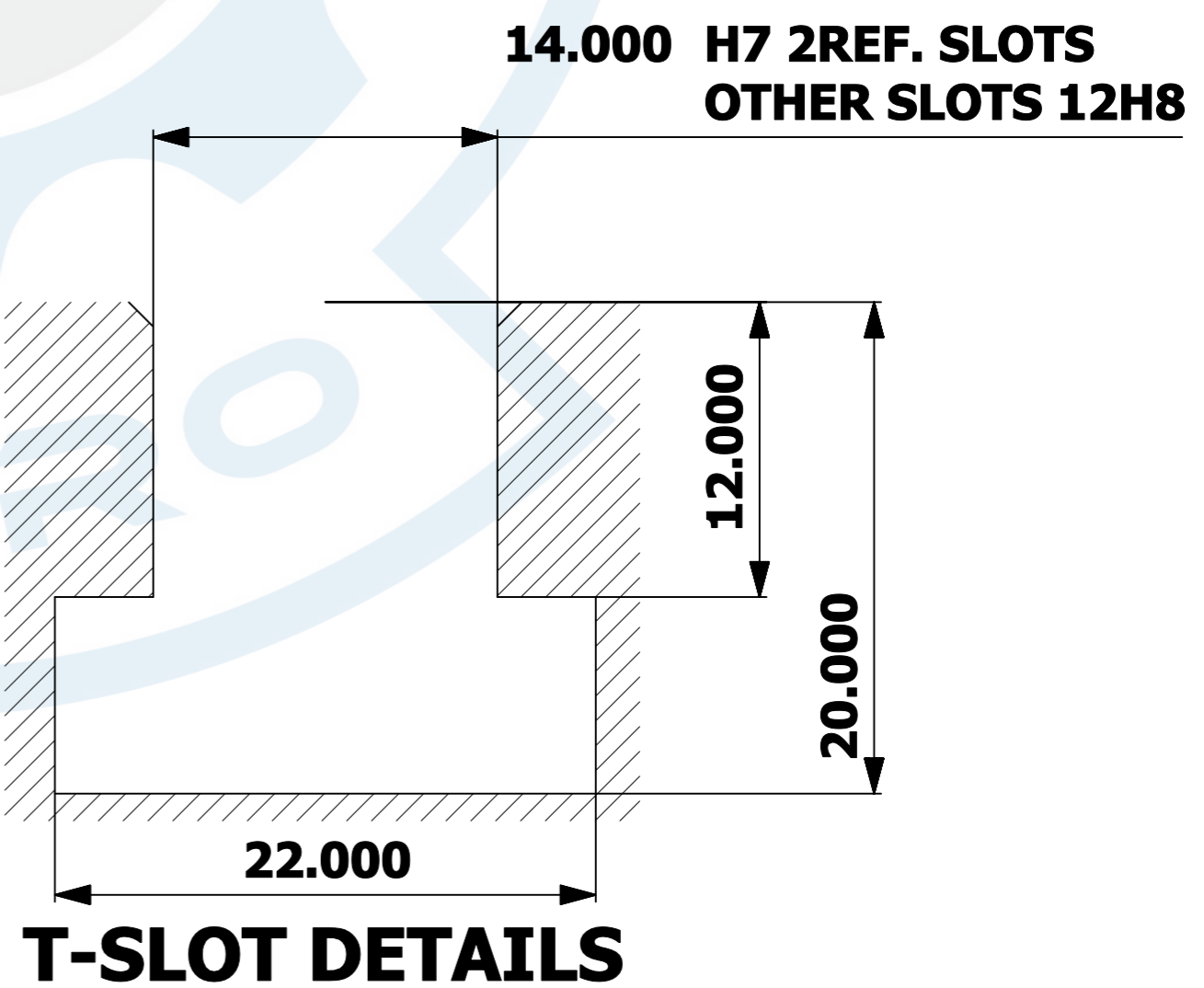
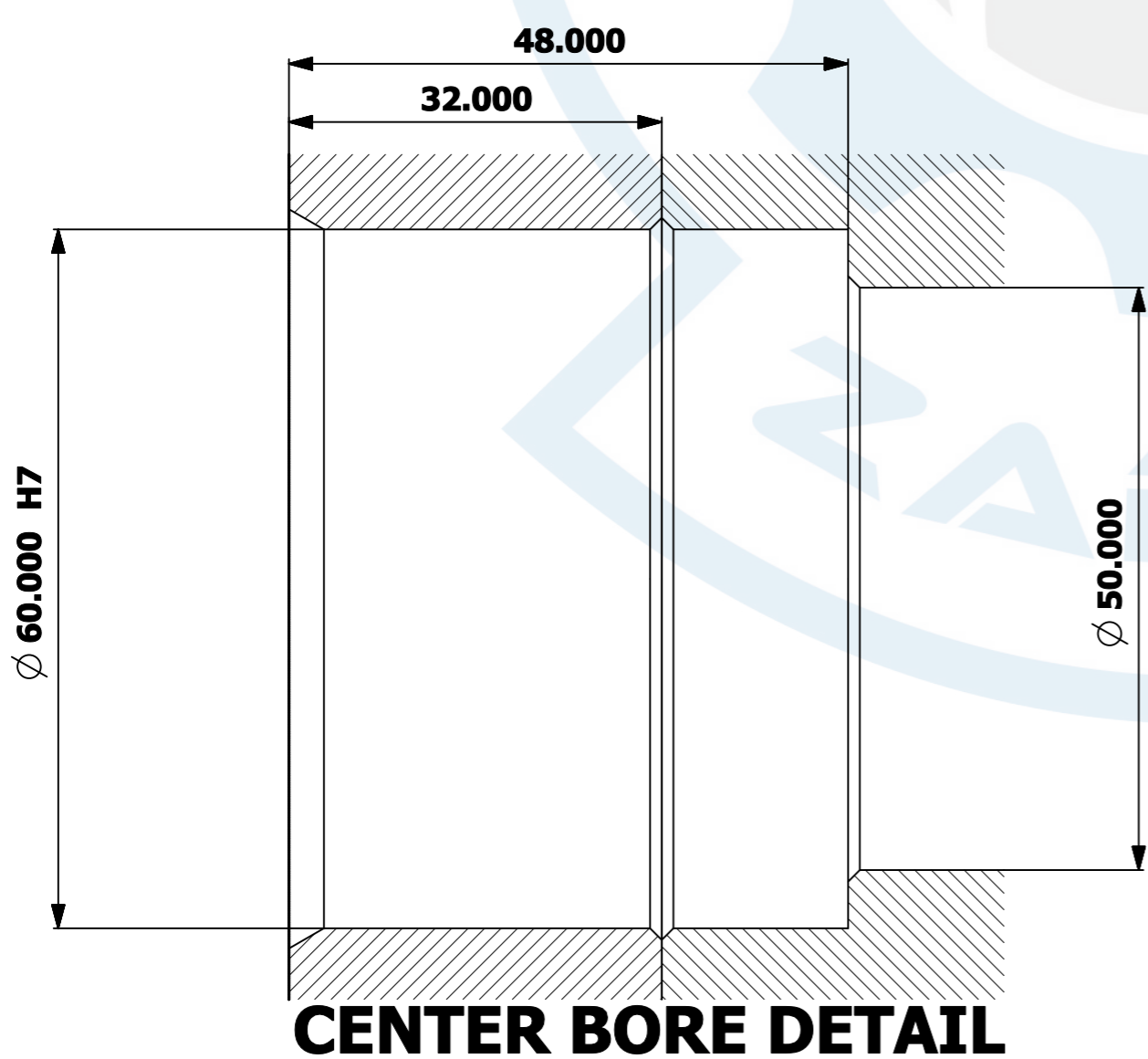
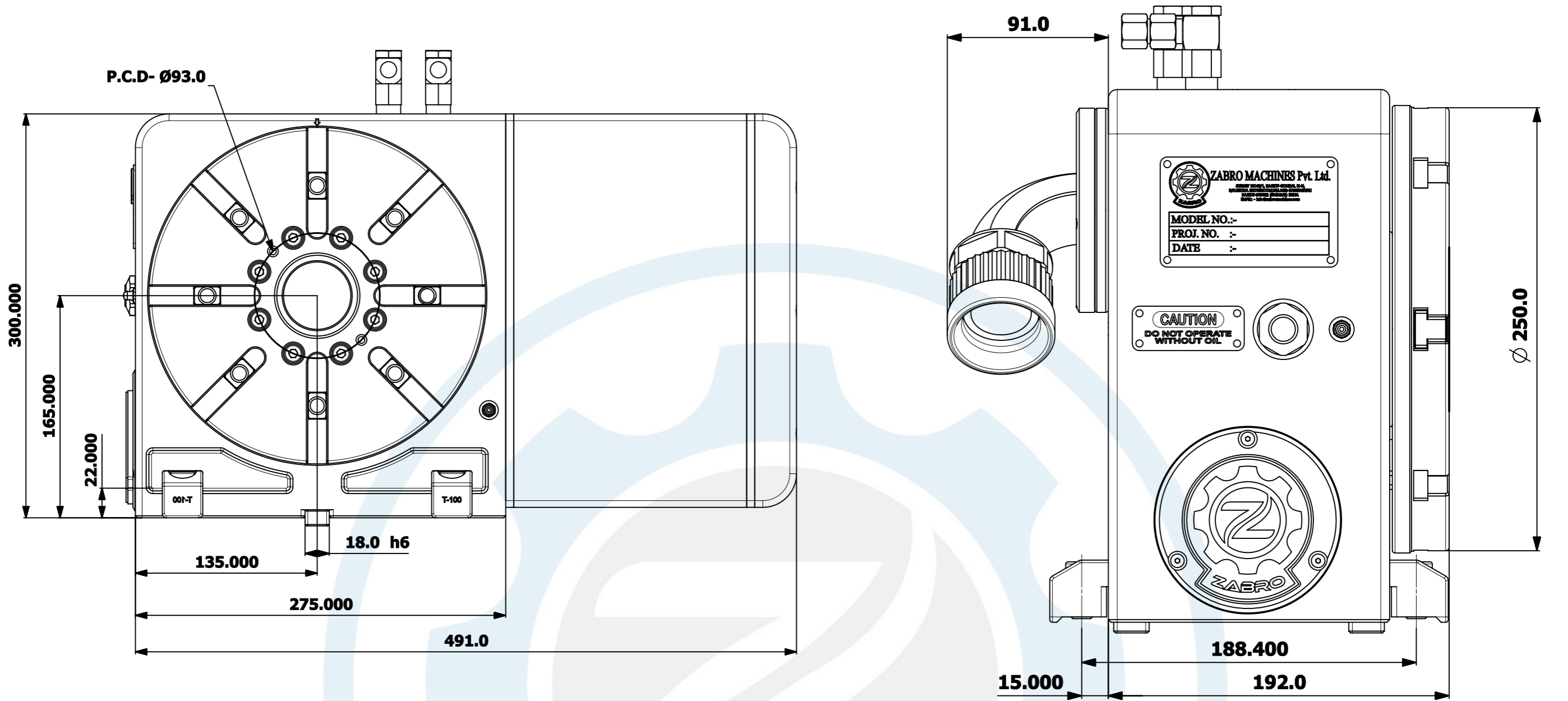

# ZRT-200

## RIGHT HAND MOTOR MOUNTING

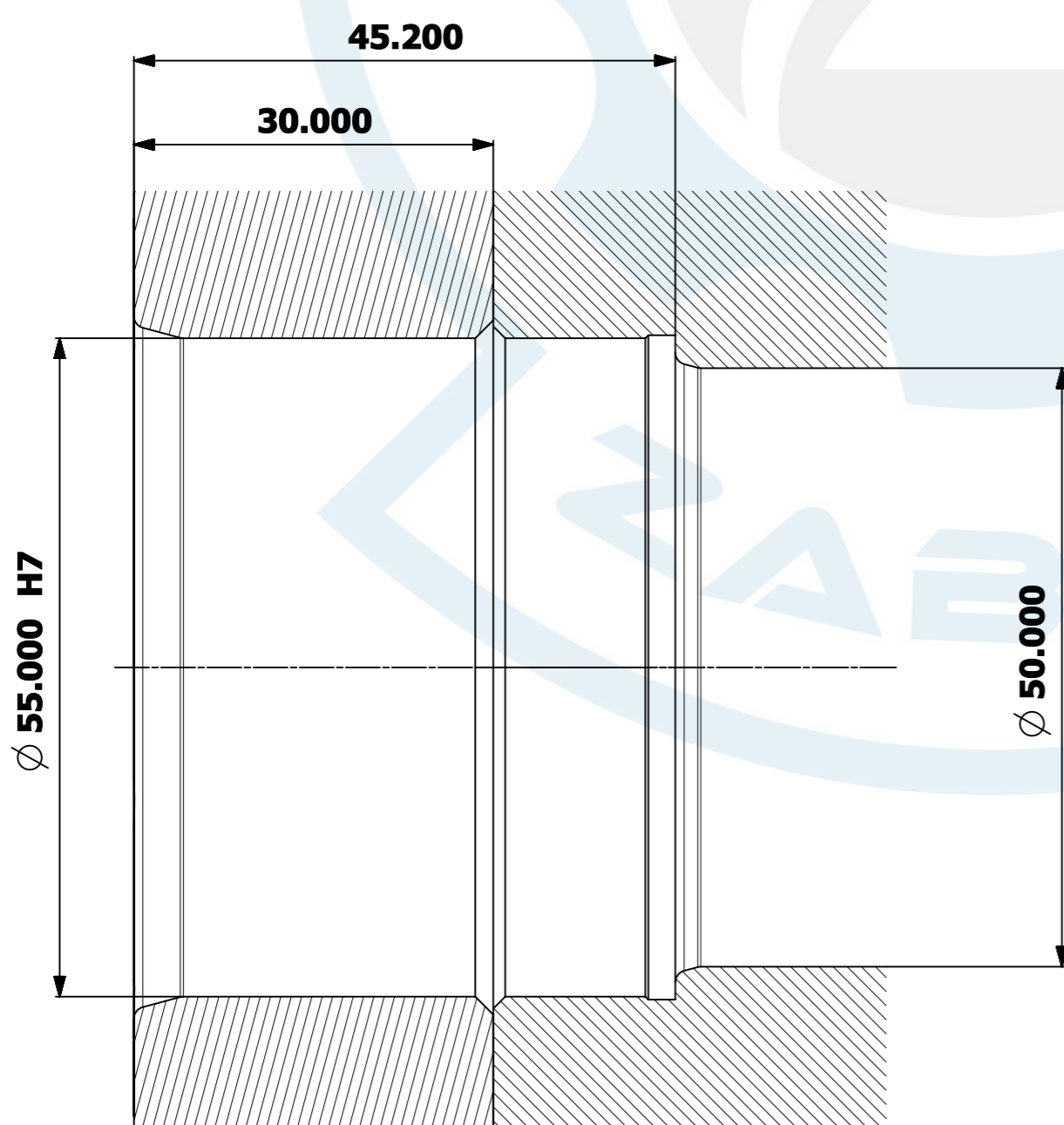
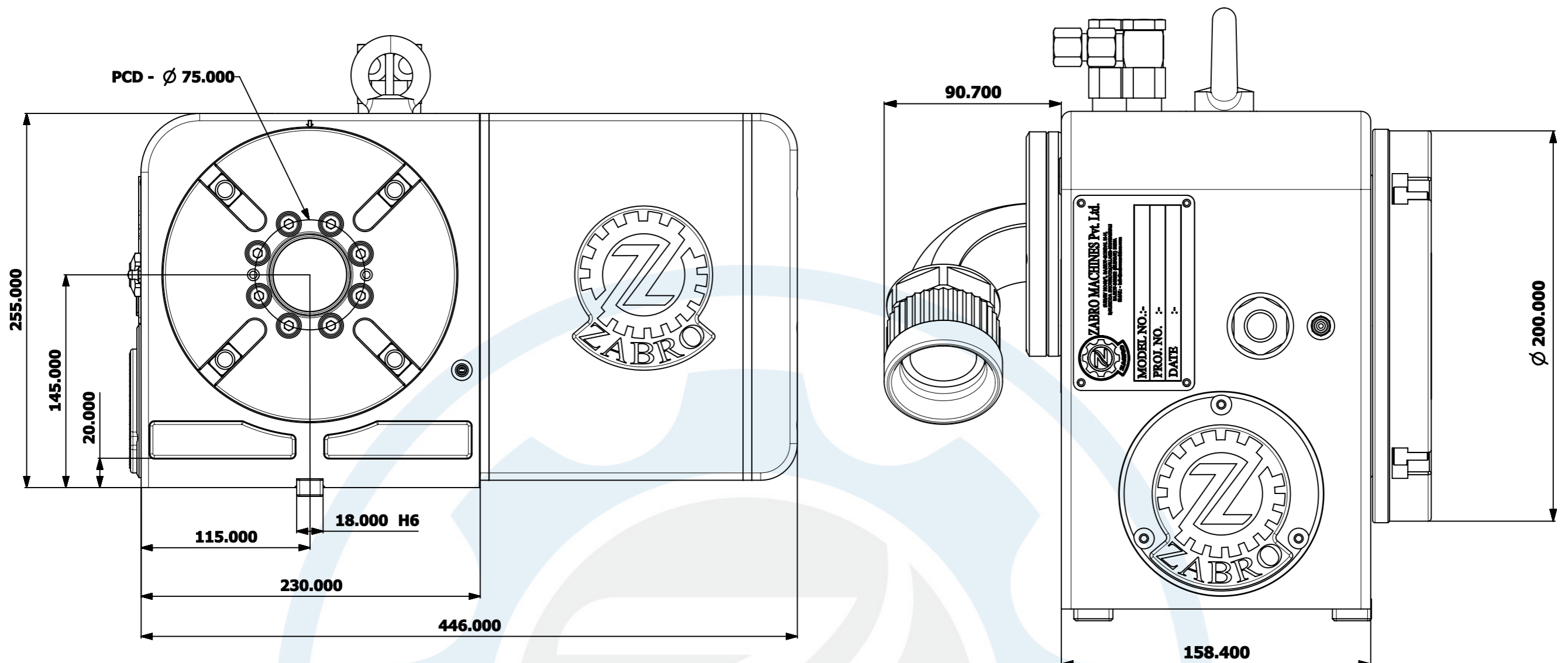

**CENTER BORE DETAIL**

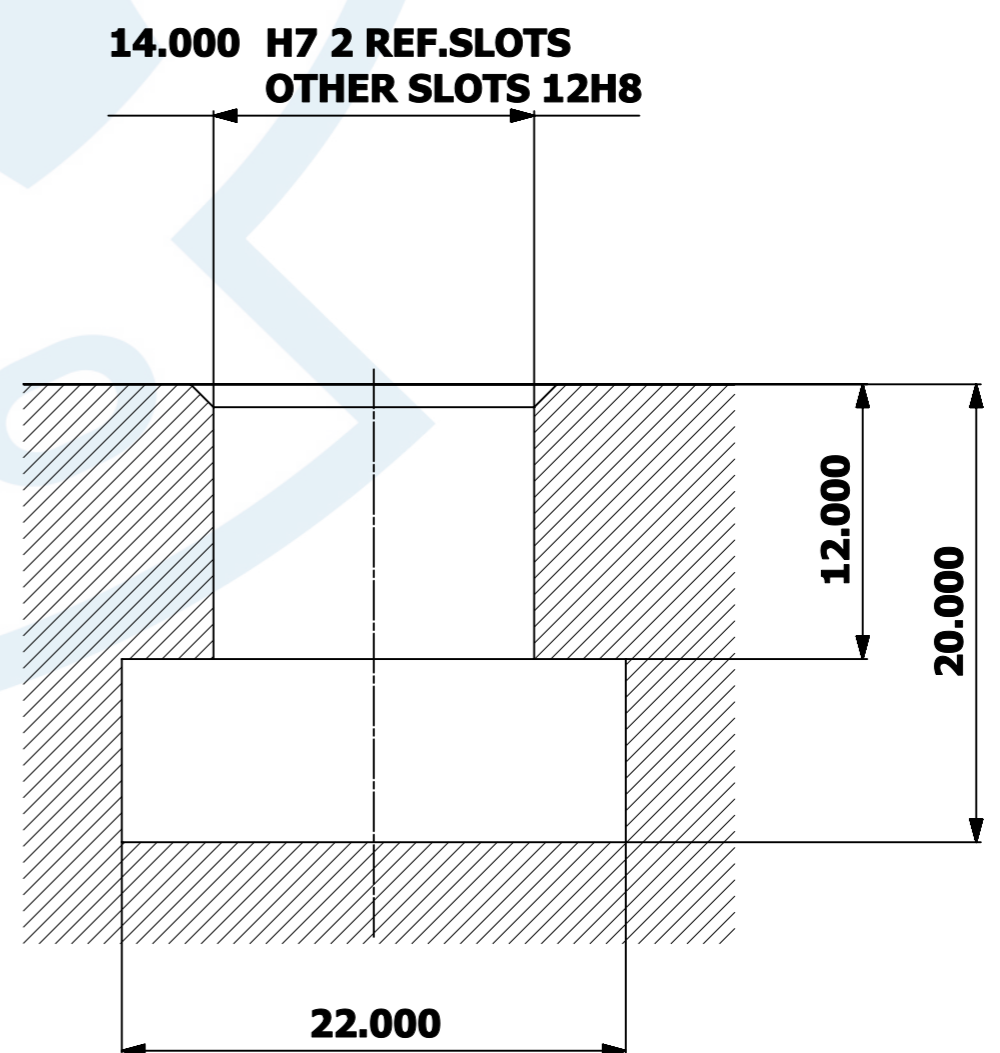

**T-SLOTS DETAILS**

# ZRT SPECIFICATION

DIMENSION		UNIT	ZRT-200	ZRT-250
	TABLE Ø	mm	200	250
	CENTER HEIGHT	mm	145	165
	CENTER BORE Ø	mm	55	60
	T-SLOT SIZE	mm	14	14
	TENON SIZE	mm	18	18
	NET WEIGHT	Kg	95	124

  

FUNCTION		UNIT	ZRT-200	ZRT-250	
	MOTOR TORQUE	Nm	4	5	
	CLAMPING FORCE	PNEUMATIC @6BAR	Nm	400	450
		HYDRAULIC @30 BAR	Nm	900	1100
	ROTATION SPEED <small>(INPUT MOTOR 3000rpm)</small>	R/m	33	25	
SPEED RATIO	-	1:90	1:120		

ACCURACIES		UNIT	ZRT-200	ZRT-250
	INDEXABILITY	deg	0.001°	0.001°
	INDEXING ACCURACY	Arc Sec	±20"	±20"
	REPEATABILITY	Arc Sec	4"	4"
	RUNOUT	RADIAL	µm	10
AXIAL		µm	10	10

LOAD		UNIT	ZRT-200	ZRT-250	
	ALLOWABLE MASS	HORIZONTAL 	Kg	300	400
		VERTICAL 	Kg	150	200
		WITH FACEPLATE 	Kg	300	400

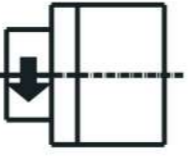
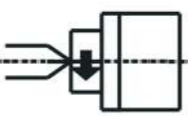

## Contact us

### ZABRO MACHINES PVT. LTD.

Survey No. 40/1, B/h. Skoda Showroom,  
Rajkot - Gondal National Highway,  
Village : Kangashiyali, Rajkot - 360 022, Gujarat (INDIA)  
E-mail : [Info@conceptfixture.com](mailto:Info@conceptfixture.com)  
Web. : [www.conceptfixture.com](http://www.conceptfixture.com)

CUSTOMER SUPPORT - Mr. Kumar Zala +91 85111 05838  
TECHNICAL SUPPORT - Mr. Sanjay Zala +91 96620 99442  
CUSTOMER SERVICE - Mr. Rahul Zala +91 96240 88365